

MSZ-HR R32

Classic Wall Mounted System

Inverter Heat Pump

Mseries

Mitsubishi Electric's HR range of wall mounted split systems is now available in capacities up to 7.1kW (24,000 BTU), making them ideal for light commercial applications such as small offices & retail spaces. With efficient & quiet operation, as well as integrated Wi-Fi control, these systems provide excellent value for money.

R32

Key Features & Benefits:

- Stylish white design
- Utilises lower GWP R32 refrigerant
- Energy efficient
- Quiet operation
- Integrated Wi-Fi interface enabling control & monitoring via the MELCloud app
- Daily timer for greater control of scheduling





MSZ-HR INDOOR UNITS		MSZ-HR35VF	MSZ-HR42VF	MSZ-HR50VF	MSZ-HR60VF	MSZ-HR71VF
CAPACITY (kW)	Heating (nominal)	3.6 (0.9-3.7)	4.7 (0.9 - 5.4)	5.4 (1.4-6.5)	6.8 (1.5-9.0)	8.1 (1.5-9.0)
	Cooling (nominal)	3.4 (0.9-3.4)	4.2 (1.1 - 4.6)	5.0 (1.3-5.0)	6.1 (1.7-7.4)	7.1 (1.8-7.4)
	Btu/h	12,000	15,000	18,000	21,000	24,000
SHF (nominal)		0.78	0.75	0.73	0.79	0.74
COP / EER (nominal)		3.69 / 2.81	3.69 / 3.10	3.48 / 2.44	3.76 / 3.37	3.32 / 3.05
SCOP / SEER (BS EN14825)		4.30 / 6.20	4.30 / 6.50	4.30 / 6.50	4.50 / 7.20	4.30 / 7.00
ErP ENERGY EFFICIENCY CLASS	Heating/Cooling	A+ / A++		A+ / A++		A+ / A++
AIRFLOW (l/s)	Heating/Cooling - Lo-Mi-Hi-SH#	55-90-123-175/60-93-130-195	93-131-180-223/100-145-180-218	102-138-187-242/107-153-187-218	178-218-278-327/173-210-257-327	178-218-278-327/173-210-257-327
PIPE SIZE mm (in)	Gas	9.52 (3/8")	9.52 (3/8")	9.52 (3/8")	12.7 (1/2")	12.7 (1/2")
	Liquid	6.35 (1/4")	6.35 (1/4")	6.35 (1/4")	6.35 (1/4")	6.35 (1/4")
SOUND PRESSURE LEVEL (dBA)	Heating/Cooling - Lo-Mi-Hi-SH#	21-30-37-44/22-31-38-46	24-32-40-46/24-34-39-45	27-34-41-47/28-36-40-45	33-38-44-50/33-38-44-50	33-38-44-50/33-38-44-50
SOUND POWER LEVEL (dBA)		60	60	60	65	65
DIMENSIONS (mm)	Width x Depth x Height	838 x 228 x 280	838 x 228 x 280	838 x 228 x 280	923 x 263 x 305	923 x 263 x 305
WEIGHT (kg)		8.5	9	9	12.5	12.5
ELECTRICAL SUPPLY		Fed by Outdoor Unit		Fed by Outdoor Unit		Fed by Outdoor Unit
FUSE RATING (BS88) - HRC (A)		6	6	6	6	6
INTERCONNECTING CABLE No. CORES		4	4	4	4	4

Note: Remote control included as standard with all wall mounted units.

MSZ-HR OUTDOOR UNITS		MUZ-HR35VF	MUZ-HR42VF	MUZ-HR50VF	MUZ-HR60VF	MUZ-HR71VF
SOUND PRESSURE LEVEL (dBA)	Heating/Cooling	51 / 51	51 / 51	51 / 50	57 / 53	57 / 53
SOUND POWER LEVEL (dBA)	Cooling	64	63	64	65	66
WEIGHT (kg)		24	34	35	40	40
DIMENSIONS (mm)		699 x 249 x 538	800 x 285 x 550	800 x 285 x 550	800 x 285 x 714	800 x 285 x 714
ELECTRICAL SUPPLY		220-240v, 50Hz	220-240v, 50Hz	220-240v, 50Hz	220-240v, 50Hz	220-240v, 50Hz
PHASE		Single	Single	Single	Single	Single
SYSTEM POWER INPUT (kW)	Heating/Cooling (nominal)	0.98 / 1.21	1.30 / 1.34	1.55 / 2.05	1.81 / 1.81	2.44 / 2.33
	Heating/Cooling (UK)	0.89 / 0.96	1.19 / 1.06	1.40 / 1.62	1.63 / 1.52	2.20 / 1.96
STARTING CURRENT (A)		5.9	7.5	9.0	8.0	10.8
SYSTEM RUNNING CURRENT (A)	Heating/Cooling [MAX]	4.6 / 5.9 [6.4]	5.2 / 7.4 [8.2]	6.9 / 9.0 [9.6]	8.0 / 8.0 [14.1]	11.8 / 10.3 [14.1]
FUSE RATING (BS88) - HRC (A)		10	13	16	16	16
MAINS CABLE No. CORES		3	3	3	3	3
MAX PIPE LENGTH (m)		20	20	20	20	20
MAX HEIGHT DIFFERENCE (m)		12	12	12	12	12
CHARGE REFRIGERANT (kg) / CO ₂ EQUIVALENT (t) - R32 (GWP 675)		0.45 / 0.30	0.70 / 0.47	0.80 / 0.54	1.05 / 0.71	1.05 / 0.71
MAX ADDITIONAL REFRIGERANT (kg) / CO ₂ EQUIVALENT (t) - R32 (GWP 675)		0.26 / 0.18	0.26 / 0.18	0.26 / 0.18	0.46 / 0.32	0.46 / 0.32

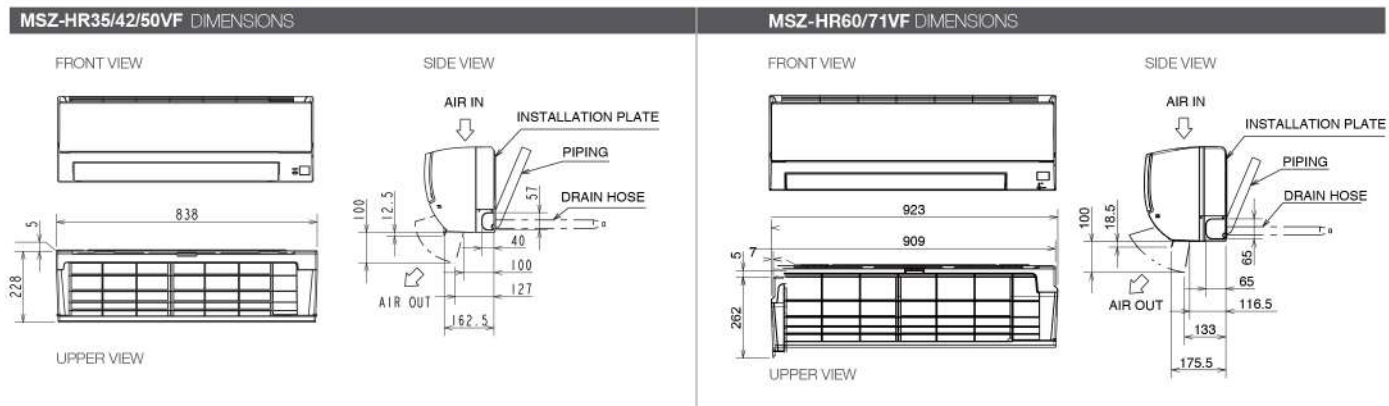

[f @kencar.net](https://www.facebook.com/kencar.net)
[@kencar_group](https://www.instagram.com/kencar_group)
[in @kencar group](https://www.linkedin.com/company/kencar-group)

Web: www.kencar.net
 E-mail: sales@kencar.net
 Tel: +356 2138 2091

